

COD. AS1R ETC USD-P

ESECUZIONE CORPO VALVOLA
BODY VALVE EXECUTION

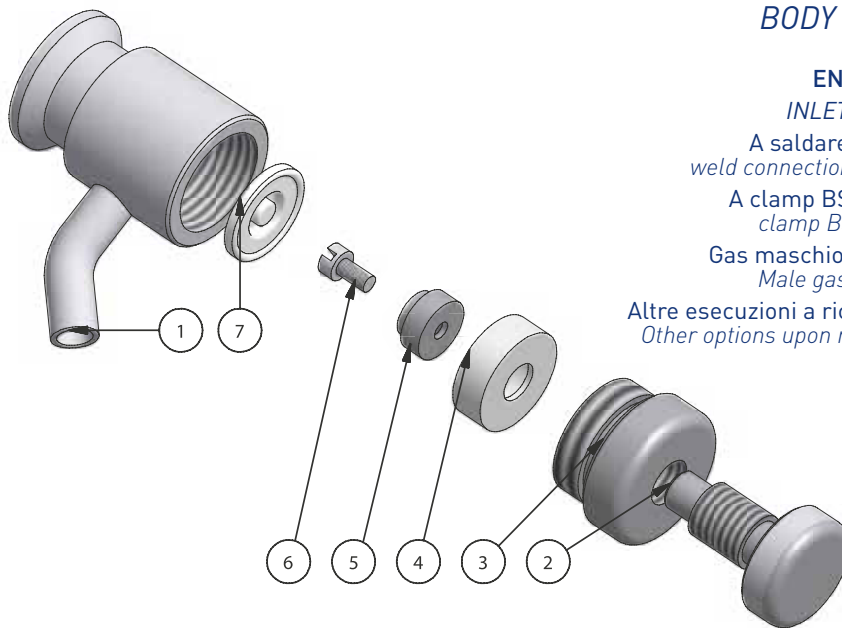

ENTRATA <i>INLET FLOW</i>	USCITA <i>OUT FLOW</i>
A saldare (ESD) <i>weld connection (ESD)</i>	Clamp BS (UTC) <i>clamp BS (UTC)</i>
A clamp BS (ETC) <i>clamp BS (ETC)</i>	A saldare (USD) <i>weld connection (USD)</i>
Gas maschio (EGM) <i>Male gas (EGM)</i>	Portagomma (UPG) <i>Rubber hose (UPG)</i>
Altre esecuzioni a richiesta <i>Other options upon request</i>	Luer (ULR) <i>Luer (ULR)</i>

FINITURE

SURFACE FINISH
Esterno lucido specchio
Interno Ra <0,4 micron
*Outside mirror polished
Inside Ra <0,4 micron*

Elenco parti / Parts list			
Elemento <i>Element</i>	Qtà <i>Quantity</i>	Descrizione <i>Description</i>	Materiale <i>Material</i>
1	1	Corpo / Body	AISI 316 L
2	1	Stantuffo / Stem	AISI 303
3	1	Volantino / Hand wheel	AISI 303
4	1	Sede guarnizione / Seal	AISI 303
5	1	Pastiglia / Compressor	AISI 303
6	1	Vite / Screw	INOX A2
7	1	Guarnizione / Seal	TFM 1705 PTFE

AS1 R
CONDIZIONI MAX DI ESERCIZIO
AS1 R
MAX WORKING CONDITIONS

Temperatura / Temperature
-10°C a +150°C

Portata / Flow rate
400 Lt/h a 2 bar

Pressione nominale / Nominal pressure
Pn 10

